

GB Instruction for use

# POWERTEX



## Shackle PBSB/PBSP/PDSB/PDSP

### User Manual

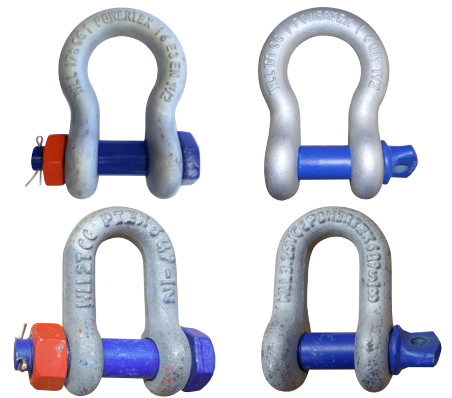

## POWERTEX Shackles Instruction for use (GB) (Original instructions)

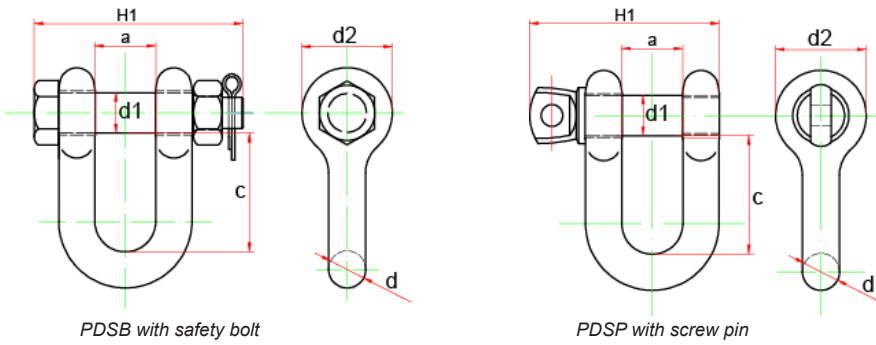

WLL ton	Pin Ø d1	a*	c*	d	d2	H1 PDSB	H1 PDSP	Weight PDSB kg	Weight PDSP kg
				mm					
0,33	6 / 6,3	10	21,85	5	14,5	33,5	29	0,027	0,025
0,5	8	13	22	6,5	17,5	42,5	38	0,05	0,042
0,75	9,5	13,5	25,5	8	21	47	42,5	0,086	0,068
1	11,2	17	30,9	10	25	56,5	51,5	0,160	0,130
1,5	12,7	18,5	36,4	11	27	63,5	58	0,215	0,185
2	15,8	20,6	41,4	12,7	30,5	75,5	67	0,340	0,29
3,25	18,8 / 19	27	51	16	40	92	85	0,6	0,58
4,75	22	32	63	19	48	106	98,5	1,02	0,93
6,5	25	37	72	22	54	120	114	1,6	1,45
8,5	28	43,5	81,75	26,5	60	135	129,5	2,3	2,06
9,5	32	48	94	29	68	143	144	3,33	2,91
12	35	53	102	32	76	164	157	4,15	4,15
13,5	38	59	113,5	35	84	182	171	5,87	5,5
17	42	62	123	38	92	195	186	7,6	6,97
25	50	75	148	45	106	224	227	11,7	11,22
35	55	84	174,5	52	122	248	253	17,84	16,36
55	70	107	205,5	66	145	302	318	33	31

\*Tolerance: +/- 5%

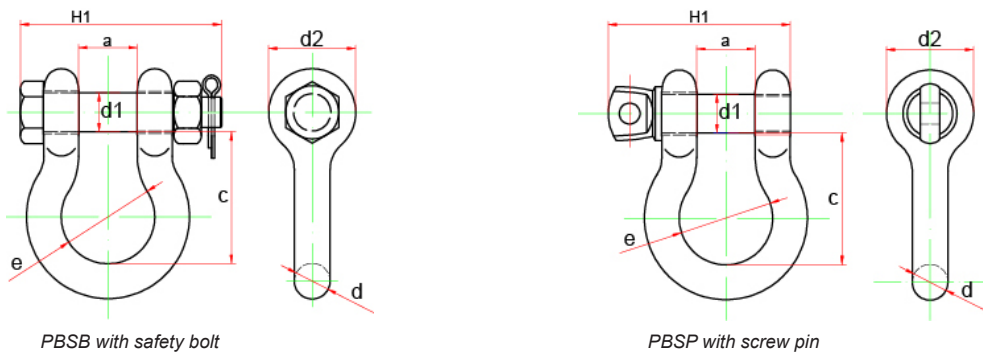

WLL tons	Pin Ø d1	a*	c*	d	d2	e	H1 PBSB	H1 PBSP	Weight kg
				mm					
0,33	6 / 6,3	10	22,6	5	14,5	15,5	33,5	29	0,026
0,5	8	13	29	6,5	17,5	20	42,5	38	0,048
0,75	9,5	13,5	31	8	21	21,5	47	42,5	0,082
1	11,2	17	36,5	10	25	26,2	56,5	51,5	0,150
1,5	12,7	18,5	42,9	11,3	27	29,5	63,5	58	0,20
2	15,8	20,6	47,75	12,7	30,5	33,3	75,5	67	0,30
3,25	18,8 / 19	27	60	16	40	43	92	85	0,65
4,75	22	32	71,5	19	48	51	106	98,5	1,01
6,5	25	37	84,5	22	54	58	120	114	1,5
8,5	28	43,5	96,25	26,5	60	68,5	135	129,5	2,25
9,5	32	48	109	29	68	75	143	144	3,25
12	35	53	120,5	32	76	84	164	157	4,45
13,5	38	59	134	35	84	94	182	171	5,95
17	42	62	148,5	38	92	99	195	186	7,72
25	50	75	178	45	106	128	224	227	12,64
35	55	84	197,5	52	122	148	248	253	18,72
55	70	107	269,5	66	145	186	302	318	37
85	80	130	325	76	165	205	395	382	58

\*Tolerance: +/- 5%

## WARNING

- Failure to follow the regulations of this mounting instruction may cause serious consequences such as risk of injury.
- Read and understand these instructions before use.

### 1. General description:

POWERTEX Shackles are used as removable links to connect steel wire rope used in lifting operations and static systems, chain and other fittings. Screw pin shackles are used mainly for non-permanent applications. Safety bolt shackles are used for long-term or permanent applications or where the load may slide on the pin causing rotation of the pin.

Dee shackles are mainly used on one-leg systems whereas anchor- or bow shackles are mainly used on multi-leg systems.

### 2. Marking

Powertex shackles are generally marked with:

- Working Load Limit e.g. WLL 25t.
- Steel grade e.g. 6.
- Manufacturer's symbol e.g. Powertex, PTEX or PX.
- Traceability code e.g. F3 (indicating a particular batch).
- Conformity code **CE** + **UK**

Additional Powertex shackles are marked with the following:

- size in inches e.g. 1 3/4.
- arrows to indicate 45 degree angle.
- according to EN 13889: EN (from 2t and up).

raised pad (on the back) for individual stamping



Powertex shackles meet all relevant requirements of the Machinery Directive 2006/42/EC and its latest amendments.

### 3. Finish

Powertex Shackles are hot dipped galvanized.

### 4. Certification

Powertex shackles are in compliance with:

- EN 13889
- AS 2741
- US Federal Specification RR-C-271

Although EN 13889 only cover the range of Working Load Limits 0,5 t to 25 t maximum, the Powertex shackles are all manufactured according to EN 13889.

### 5. Testing

Powertex shackles are proofload tested at WLL x 2.

### 6. Instruction for use

Select the correct type and WLL of shackle and WLL for the particular application. If extreme circumstances or shock loading may occur, this must be well taken into account when selecting the correct shackle. Please note that commercial shackles are not to be used for lifting applications.

### 7. Assembly

Shackles should be inspected before use to ensure that (if criterias are not in place, the shackle must be rejected):

- a) the body and the pin of the shackle are both identifiable as being of the same size, type and mark;
- b) all markings are readable;
- c) the threads of the pin and the body are undamaged;
- d) the body and pin are not distorted;
- e) the body and pin are not unduly worn;
- f) the body and pin are free from nicks, gouges, cracks and corrosion.
- g) never use a safety bolt type shackle without using a secure pin.
- h) shackles may not be heat treated as this may affect their WLL.
- i) never modify, repair or reshape a shackle.

Ensure, where appropriate, that the pin is correctly screwed into the shackles eye, i.e. tighten finger tight, then lock using a small tommy bar

or suitable tool so that the collar of the pin is seated on the shackle eye. Ensure that the pin is of the correct length so that it penetrates the full depth of the screwed eye and allows the collar of the pin to bed on the surface of the drilled eye.

In all cases, when the pin is correctly fitted in the body of the shackle, the jaw width A should not be significantly reduced.

Incorrect seating of the pin may be due to a bent pin, the thread fitting too tightly or misalignment of pin holes. Do not use the shackle under these circumstances.

Never replace a shackle pin except with one of the same size type and mark as it may not be suitable for the loads imposed.

### 8. Usage

Select the correct type of shackle for a particular application from the information given in the below mentioned situations:

Shackles should not be used in a manner that imposes a side loading unless specifically permitted by the manufacturer. In general this means that the shackle body should take the load along the axis of its centreline. (See figure A.1).

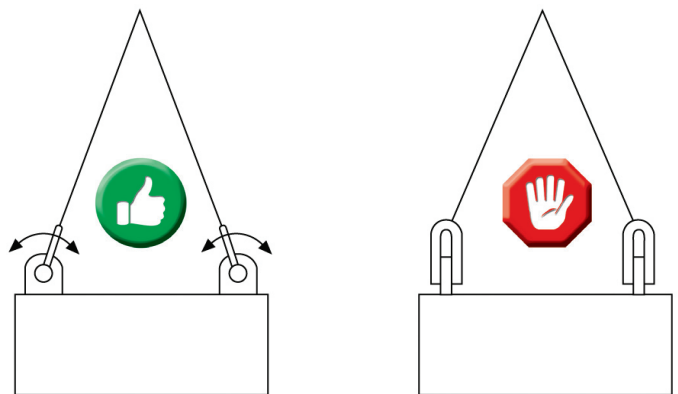

Fig. A.1

When using shackles in conjunction with multi-leg slings, due consideration should be given to the effect of the angle between the legs of the sling. As the angle increases so does the load in the sling leg and consequently in any shackle attached to the leg.

When a shackle is used to connect two slings to the hook of a lifting machine, it should be a bow type shackle assembled with the slings in the shackle body and the hook engaged with the shackle pin. The included angle between the slings should not exceed 120°.

To avoid eccentric loading of the shackle a loose spacer may be used on either end of the shackle pin (see figure A.2). Do not reduce the width between the shackle jaws by welding washer or spacers to the inside faces of the eyes or by closing the jaws, as this will have an adverse effect on the properties of the shackle.

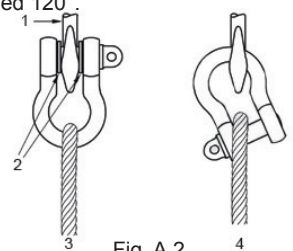

Fig. A.2

When a shackle is used to secure the top block of a set of rope blocks the load on this shackle is increased by the value of the hoisting effect.

Avoid applications where due to movement (e.g. of the load or the rope) the shackle pin can roll and possibly unscrew. (See figures A.3 and A.4).

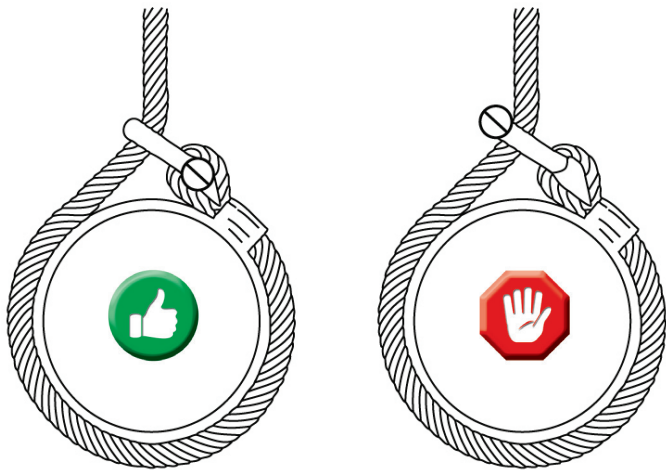

Fig. A.3

Correct: Shackle pin cannot turn      Incorrect: shackle pin bearing on running line can work loose

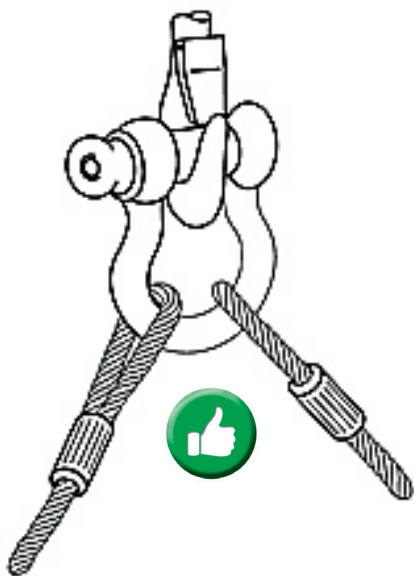

Fig. A.4

Correct - use two ropes with eyes

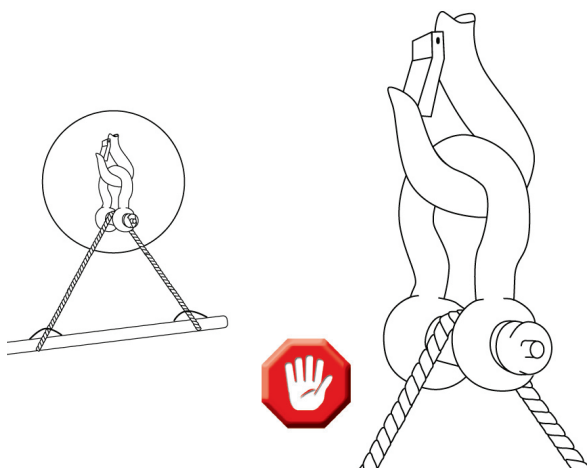

Fig. A.4

Incorrect - the load is unstable and if the load shifts the sling will unscrew the shackle pin.

In applications where the shackle is to be left in place for a prolonged period or where maximum pin security is required, use a bolt with hexagon head, hexagon nut and split cotter pin..

Avoid applications where the load is unstable (See figure A.4).

Shackles should not be modified, heat treated, galvanized or subject to any plating process without the approval of the manufacturer.

Do not use a shackle outside the temperature range of -20°C to +200°C without consulting the manufacturer.

Shackles should not be immersed in acidic solutions or exposed to acid fumes or other chemicals without the approval of the manufacturer. Attention is drawn to the fact that certain production processes involve acidic solutions, fumes etc. and in these circumstances the manufacturer's advice should be sought.

The rating of shackles to EN 13889 assumes the absence of exceptionally hazardous conditions. Exceptionally hazardous conditions include offshore activities, the lifting of persons and lifting of potentially dangerous loads such as molten metals, corrosive materials or fissile materials. In such cases the degree of hazard should be assessed by a competent person and the safe working load reduced accordingly from the working load limit.

## 9. Side loads

Side loads should be avoided, as the products are not designed for this purpose. If side loads cannot be avoided, the WLL of the shackle must be reduced:

Load angle	Reduction for side loading New Working Load Limit
0°	100% of original WLL
45°	70% of original WLL
90°	50% of original WLL

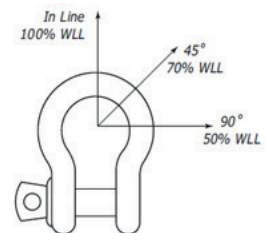

In-line lifting is considered to be a load perpendicular to the pin and in the plane of the bow. The load angles in the table are the deviating angles from the in-line loads.

When using shackles in connection with multi-leg slings, due consideration should be given to the effect of the angle between the legs of the sling. As the angle increases, so does the load in the sling leg and consequently in any shackle attached to that leg.

## End of use/Disposal

PowerTex shackles shall always be sorted / scrapped as general steel scrap.

Main material is steel grade 6, and hot dip galvanized. Split is AISI 304. The supplier will assist you with the disposal, if required.

**Must be inspected at least once a month and must undergo a complete overhaul at least every 12 months. Please note local rules and regulations must be complied with regards to inspection.**

## Disclaimer

We reserve the right to modify product design, materials, specifications or instructions without prior notice and without obligation to others.

If the product is modified in any way, or if it is combined with a non-compatible product/component, we take no responsibility for the consequences in regard to the safety of the product.

## Declaration of conformity

SCM Citra OY  
Asessorinkatu 3-7  
20780 Kaarina  
Finland  
www.powertex-products.com  
hereby declares that POWERTEX product as described above is in compliance with EC Machinery Directive 2006/42/EC.

## UK Declaration of conformity

SCM Citra OY  
Asessorinkatu 3-7  
20780 Kaarina, Finland  
www.powertex-products.com  
hereby declares that the POWERTEX product as described above is in compliance with the Supply of Machinery (Safety) Regulations 2008.

## CertMax+

The CertMax+ system is a unique leading edge certification management system which is ideal for managing a single asset or large equipment portfolio across multiple sites. Designed by the Lifting Solutions Group, to deliver optimum asset integrity, quality assurance and traceability, the system also improves safety and risk management levels.

---



## User Manuals

You can always find the valid and updated User Manuals on the web. The manual is updated continuously and valid only in the latest version.

**NB!** The English version is the Original instruction.

The manual is available as a download under the following link:  
[www.powertex-products.com/manuals](http://www.powertex-products.com/manuals)

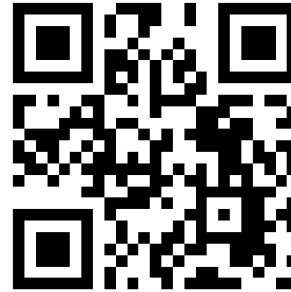

# POWERTEX

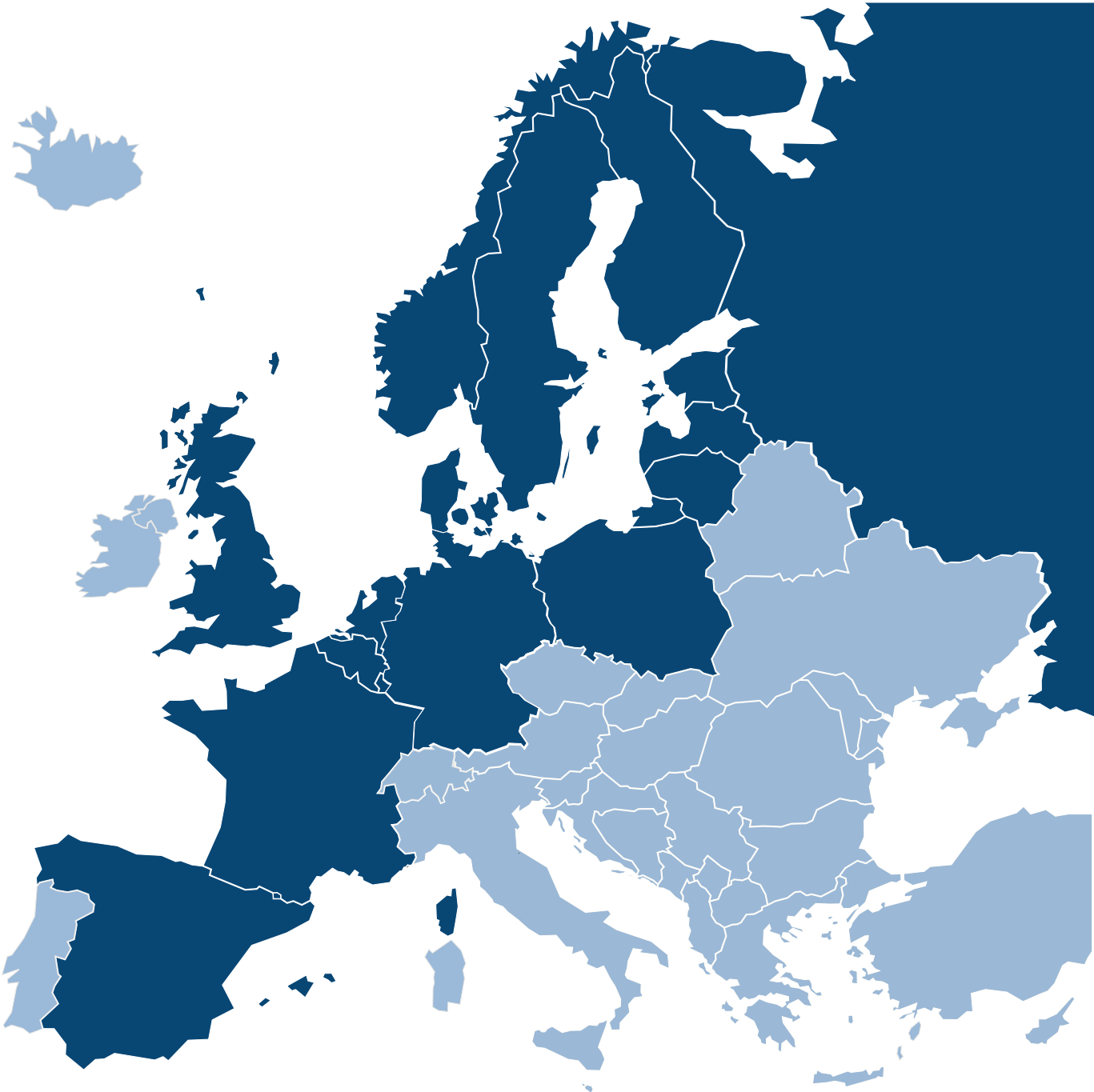

[www.powertex-products.com](http://www.powertex-products.com)